

# PPROCAMCQ

## Vision Systems – Camera P3

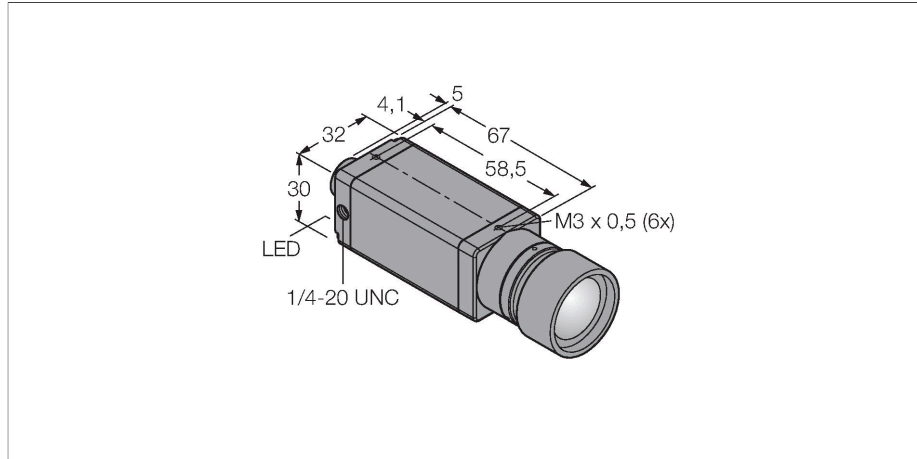

### Features

- Compact camera (separate controller required, type PPROCTL)
- protection class IP20
- Lens to be ordered separately
- 1/3" CMOS, 752x480 pixels
- RGB- / HSI color space

### Wiring diagram

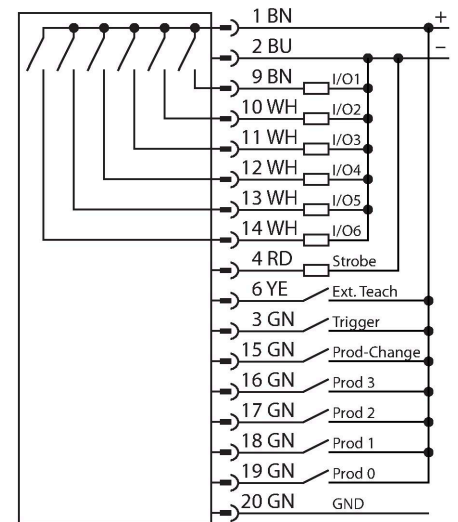

### Functional principle

The image processing system PresencePLUS PRO consists of the compact camera and the processing unit incorporated in a separate controller. Lens, external/internal lighting and connection cable are to be ordered separately. Freeware and firmware updates are available for download on: [www.bannerengineering.com](http://www.bannerengineering.com)

### Technical data

Type	PPROCAMCQ
ID	3083484
<b>Camera data</b>	
Resolution	752 x 480 Pixels
Brennweite	8 mm
DC rated operational current	≤ 550 mA
Communication protocol	EtherNet/IP Modbus TCP Modbus TCP PCCC RS232
<b>Mechanical data</b>	
Dimensions	72 x 30 x 32 mm
Housing material	Metal, AL
Ambient temperature	0...+50 °C
<b>Tests/approvals</b>	
Approvals	CE

### Accessories

Dimension drawing	Type	ID
	PPC06	3062409
	PPC06RA	3070827