

excom I/O System

Input Module, Analog, Active, HART, 4-channel

AIH40-N

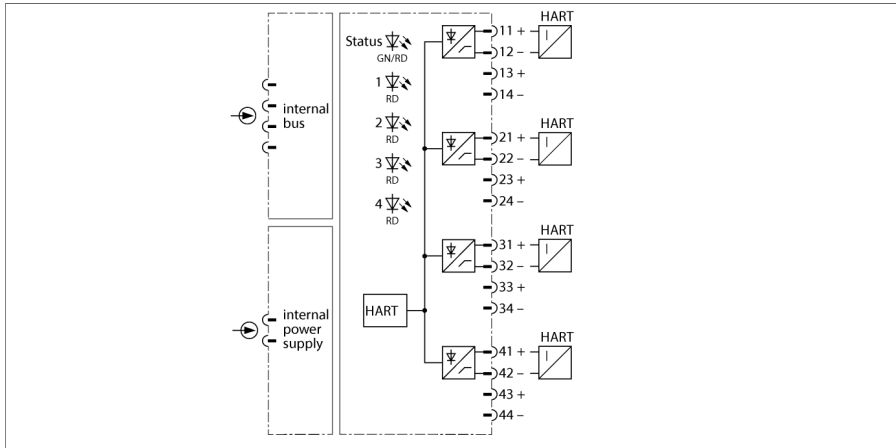

The input module AIH40-N is used for the connection of 2-wire transducers (active input = source mode / transducer passive).

The inputs are not galvanically isolated from each other. When connecting the field devices, care has to be taken that all outputs are on the same potential.

HART-compatible sensors can be connected to the module; these will communicate with the integrated HART controller.

The resolution is 14 bit, i.e. the analog value between 0...21 mA is represented as a number between 0 and 16383. For clear reading, the digitized value is displayed in a range of 0...21000 and transmitted to the host system.

Up to 8 HART variables (max. 4 per channel) can be read via the cyclical PROFIBUS data traffic. The bidirectional exchange of variables between the host system and the HART transmitter is implemented via PROFIBUS-DPV1.

Setting the parameters, such as wire-break/ short-circuit monitoring, measuring range, HART communication, etc., can be carried out channel-by-channel and is initiated exclusively by the PROFIBUS master.

- Input module for connection of 2-wire transmitters
- Transmission of HART data

Dimensions

Type	AIH40-N
ID	6884219
Supply voltage	Via module rack, central power supply module
Power consumption	≤ 3 W
Galvanic isolation	to int. bus and supply circuit
Number of channels	4
Input circuits	0/4...20 mA
Supply voltage	15 VDC at 22 mA
HART impedance	> 240 Ω
Overload capability	> 21 mA
Low level control	< 3.6 mA
Short-circuit	< 5 V (only in live zero mode)
Wire-break	< 2 mA (only in live zero mode)
Reference temperature	25 °C
Resolution	14 Bit
Temperature drift	≤ 0.005 % of full scale/K
Rise time/fall time	≤ 50 ms (10...90 %)
Max. measurement tolerance under EMC influence	≤ 0.1 % with shielded signal cable ≤ 1 % with unshielded signal cable
Displays/Operating elements	
Operational readiness	1 × green/red
State/ Fault	4 × red
Housing material	Plastic
Connection mode	module, plugged on rack
Protection class	IP20
Ambient temperature	-20...+60 °C
Relative humidity	≤ 93 % at 40 °C acc. to IEC 60068-2-78
Vibration test	Acc. to IEC 60068-2-6
Shock test	Acc. to IEC 60068-2-27
EMC	Acc. to EN 61326-1 Acc. to Namur NE21
MTTF	61 years acc. to SN 29500 (Ed. 99) 40 °C
Dimensions	18 x 118 x 106 mm



Accessories

Type code	Ident no.		Dimension drawing
excom-RMD1-BK	100020478	The resistor module prevents wire-break detection and short-circuit detection in digital input modules. For analog input modules, overflow and underflow messages are also suppressed.	